

G: Gear type pump range

G: O Style:



Material: AL | CI

Vehicle pumps

The GO range is a series of pumps that are lightweight and have double helical gears for quiet operation. They are not suitable for hazardous materials.

Features

- Pulse free flow from double helical pumping gears.
- Robust pumps, long-life with simple maintenance.
- Mechanical seal choices for solvents and other liquids.
- Simple seal replacement.
- Reversible.
- Suitable for mounting in any position.
- Relief valve fitted in body of pump.

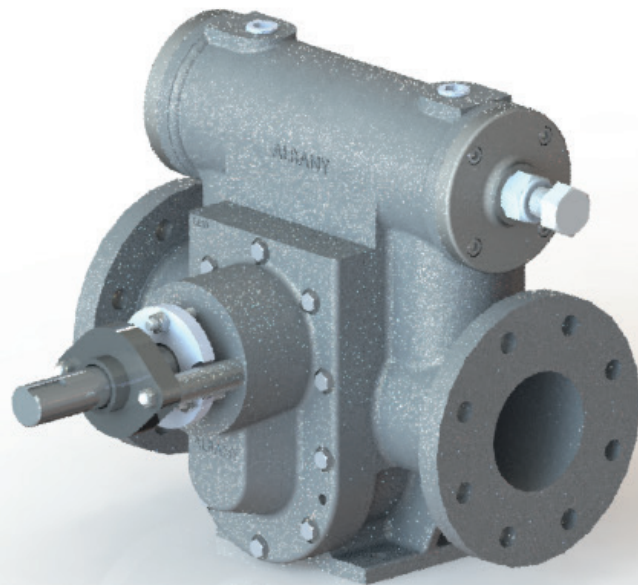

Albany's 24-page brochure is available as a download at www.albany-pumps.co.uk



Maximum working pressure 7 barg	Pump size range 2" - 4"	Maximum temperature 180°C	Flow rate 230-960 L/min
--	--------------------------------	----------------------------------	--------------------------------

AL Aluminium | CS Cast Steel | CI Cast Iron | GM Gunmetal | HY Hastelloy | NR Ni-resist | NY Nylon | PP Polypropylene | SD Super Duplex | SS Stainless Steel
 General and Chemical | Bitumen | Fire | Dispenser Machines | Food Industry | Lubrication | Marine | Oil & Gas | Refrigeration | Sugar

www.albany-pumps.co.uk +44 (0) 1594 842 275

Head Office and Manufacturing Centre

Albany Engineering Company Ltd
 Church Road, Lydney
 Gloucestershire, GL15 5EQ
 United Kingdom

t: +44 (0) 1594 842 275
 Head Office Option 1

e: salesdept@albany-pumps.co.uk

Service and Repair Centre

Albany Engineering Company Ltd
 Richter Works, Garnett Street
 Bradford BD3 9HB
 United Kingdom

t: +44 (0) 1594 842 275
 Service and Repair (Option 2).

e: servicedept@albany-pumps.co.uk

PERFORMANCE – powers and flows typical for 3.5 BARg

Pump Frame Size	95% of Theoretical output Litres/rev	Maximum viscosity 3,000 centistokes 500 RPM		Maximum viscosity 2,000 centistokes 720 RPM		Maximum viscosity 1,200 centistokes 960 RPM		Maximum viscosity 750 centistokes 1420 RPM	
		L/min	kW	L/min	kW	L/min	kW	L/min	kW
HD030	.273	136	4.0	197	4.0	264	5.5	390	7.5
HD040	0.386	195	4.1	277	5.6	368	7.5	520	8.5
HD050	0.491	245	5.6	350	7.5	473	7.5	650	9.5
HD060	0.62	310	7.5	445	7.5	600	11.2	880	14.0
HD070	0.805	405	7.5	582	11.2	773	11.2	REFER TO SALES	
HD080	1.00	509	11.2	718	11.2	955	14	REFER TO SALES	
HD100	1.32	618	11.2	950	15.0	1273	22.4		

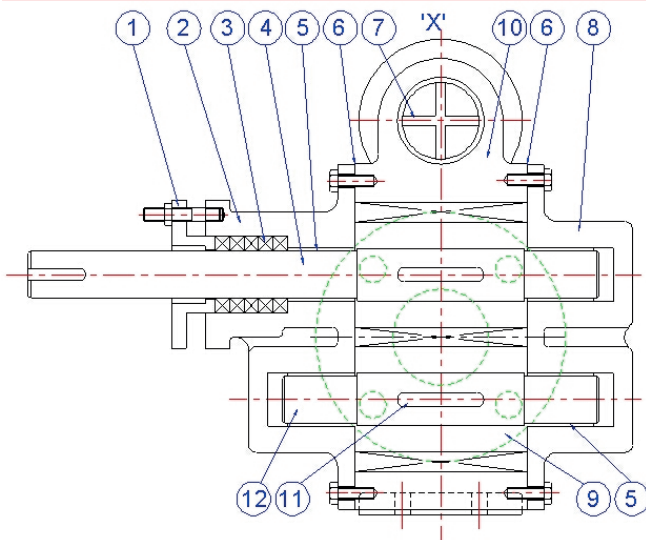

- 1 Gland
- 2 Front Cover
- 3* Gland Packing
- 4* Driving Shaft
- 5* Bushes (4 per set)
- 6* Gaskets
- 7 Relief Valve comprises...
- 8 Back Cover
- 9* Rotors (2)
- 10 Body
- 11* Key (2)
- 12* Following Shaft

PARTS LIST

- Valve
- Adjusting screw
- Locknut Spring
- Spring Header
- Fibre Washer

SPARES

Items we recommend as spares are indicated*
When ordering spares please quote pump size and the pump serial number usually stamped in position 'X'.

Maximum working pressure 7 barg	Pump size range 2" - 4"	Maximum temperature 180°C	Flow rate 230-960 L/min
--	--------------------------------	----------------------------------	--------------------------------

Albany Pumps

G: O Style:

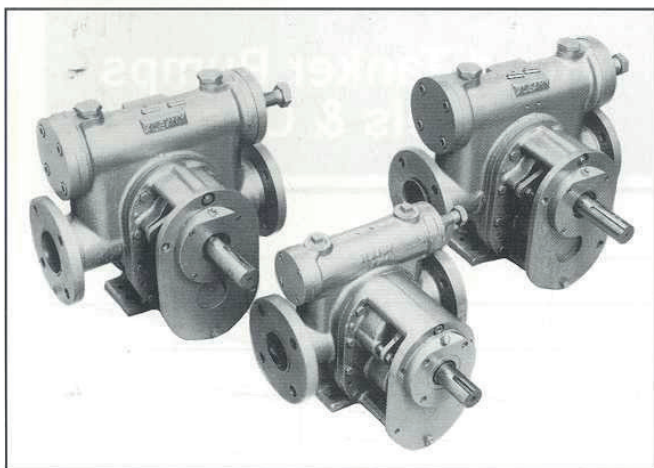

Versatile General Purpose and Special Purpose Tanker Pumps for a Wide Range of Transported Liquids

Fuel oils, lubrication oils, reclaimed oils, fuels, black oil, mineral spirits, paraffin, solvents, molasses and syrups and inks.

External bearing fitted to absorb all side loads. Simple construction: only two working parts. High viscosity capability. Self-lube bearings handle many fluids. Hardened and ground shafts ensure long life. Mechanical seal or packed gland options.

Dimensions (mm)

Pump frame size	A	A'	B	B'	C	E	F	G	H	K	L	M	N	O	P	Q	Q'	R	T
HD050	400	400	273	273	127	159	51	108	171	305	114	146	14	117	314	31.7	31.7	7.9	10
HD060	445	445	292	292	153	159	89	146	165	305	89	146	14	118	305	31.7	31.7	7.9	14
HD070	457	470	292	305	165	197	35	95	197	273	152	190	14	146	381	38	34.9	9.5	10
HD080	508	495	330	317	178	197	83	146	197	330	140	178	14	146	381	38	34.9	9.5	13

BST.D Flange Details

U	W	X	WT
2 1/2"	17	127	55kgs
3"	17	146	65kgs
3"	17	146	70kgs
3"	17	146	77kgs

Branches flanged U BST 'D', 4~W Dia holes on X pcd., thickness 19mm

A', B' & Q' apply to thrust bearing pumps on this page. A, B & Q apply to mechanical seal pumps overleaf.

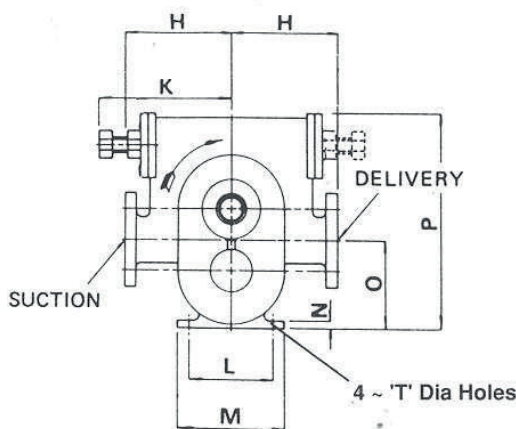
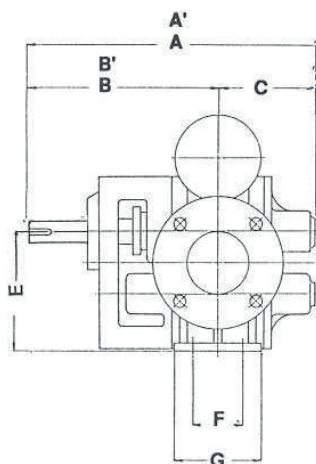

OTHER TANKER DUTIES

Additional models: 6" and 8" pumps, delivery up to 1 ton/min. of molasses are available.

Special construction: corrosion resistant pumps can be supplied in stainless steel, ni-resist cast iron and all bronze materials, contact our sales office.

Maximum working pressure 7 barg	Pump size range 2" - 4"	Maximum temperature 180°C	Flow rate 230-960 L/min
---------------------------------	-------------------------	---------------------------	-------------------------